

# RGBW Touch DMX512 Wall Control Panel

SR-2812-US3



## Feature

- 3 zones
- Sensitive Glass Touch Panel
- DMX512 Signal
- White&black
- North American Size



## Parameter

Part No.	Operation Voltage	OUTPUT	DIMENSIONS ø/h (mm)
SR-2812-US3	12-24VDC	434MHz/868MHz	120x75x29.1

## Product Size

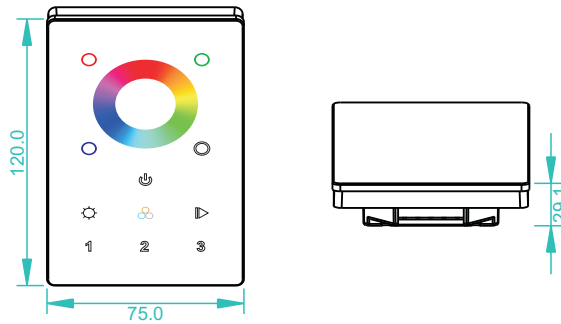

## Installation

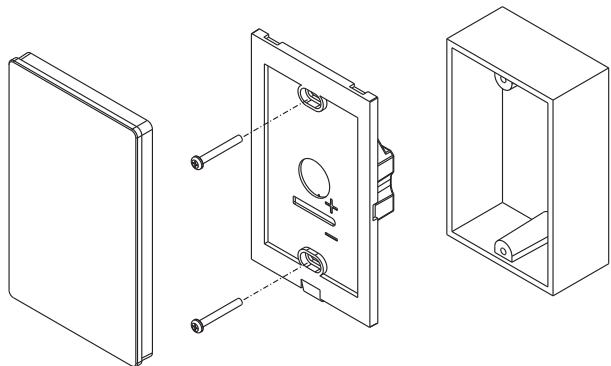

## Wiring diagram

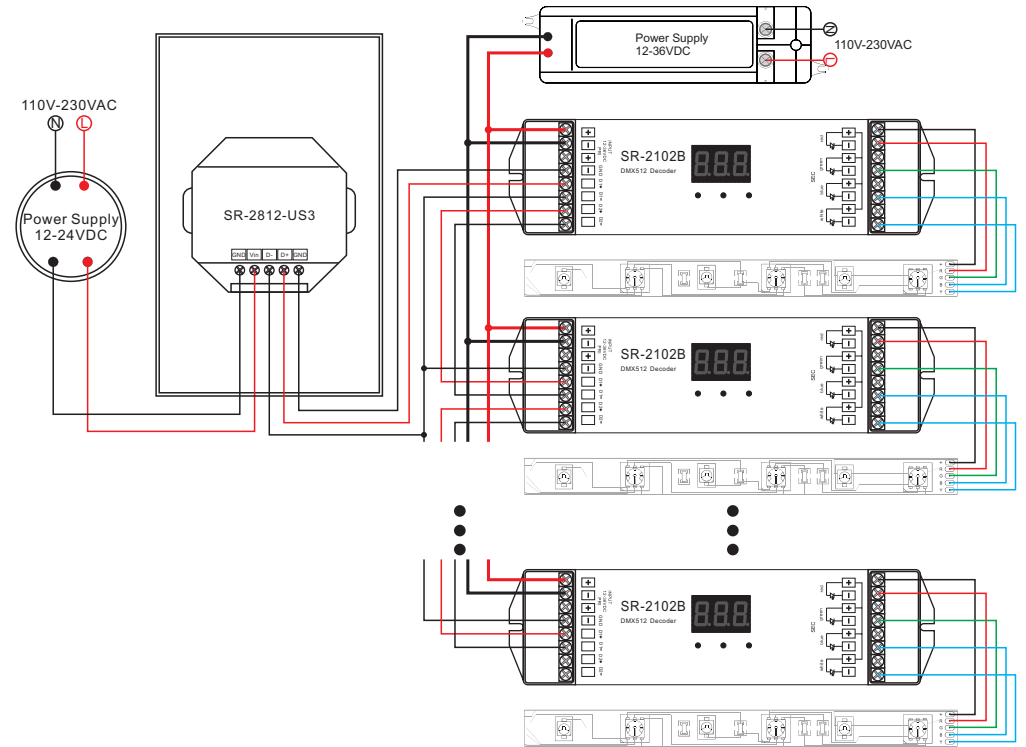

## Button introduction

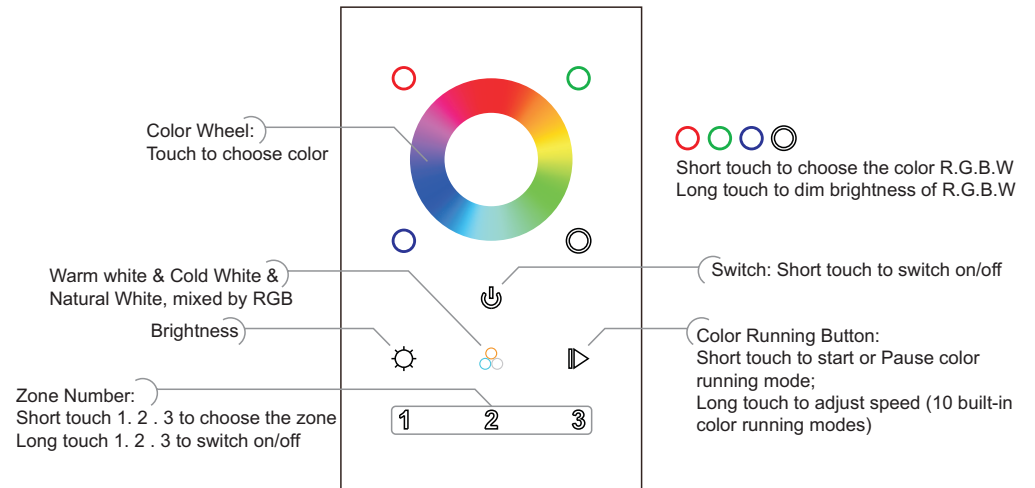

## Operation

### How to Set DMX Address ?

One SR-2812-US3 can control 3 zones separately or Synchronously

Each Zone can control DMX Decoders like our SR-2102B as many as you wish

All DMX Decoders

In Zone 1 set as 001

In Zone 2 set as 005

In Zone 3 set as 009

Note: one DMX Decoder has 4 channels take 4 DMX Address, zone one take 001, 002, 003, 004: zone 2 take 005,006.007.008, zone 3 take 009. 010.011.012

## Safety & Warnings

- 1) The product shall be installed and serviced by a qualified person.
- 2) IP20. Please avoid the sun and rain. When installed outdoors, please ensure it is mounted in a water proof enclosure.
- 3) Always be sure to mount this unit in an area with proper ventilation to avoid overheating.
- 4) Please check if the output voltage of any LED power supplies used comply with the working voltage of the product.
- 5) Never connect any cables while power is on and always assure correct connections to avoid short circuits before switching on.
- 6) Please ensure that the cable is secured tightly in the connector
- 7) For update information please consult your supplier.

## Warranty Agreement

1) We provide lifelong technical assistance with this product:

- 5-year warranty. We print date on every products, for example :1125 means year 2011, week 25. The warranty is for free repair or replacement and covers manufacturing faults only.

- For faults beyond the 5-year warranty we reserve the right to charge for time and parts.

2) Limited Warrenty

- Any defects caused by wrong operation.

- Any damages caused by unauthorized removal, maintenance, modifying, incorrect connection and replacement of chips.

- Any damages due to transportation, vibration etc. after purchase.

- Any damages caused by earthquake, fire, lightning, pollution and abnormal voltage.

- Any damages caused by negligence, inappropriate storing at high temperatures and humidity or near harmful chemicals.

- Product has been updated

3) Repair or replacement as provided under this warranty is the exclusive remedy to the customer.