

RF DIM Wall Panel Dimmer

SR-2805R(IT)



Feature

- SR-2805R(IT) is wall rotary RF dimmer with 256 levels logarithmic dimming from 0.1-100%.
- Simple and friendly use for dimming and switching ON/OFF for 1zone controlled.
- Long time span battery for 2 years
- Wireless, easy to change battery

Parameter

Remote

Part No.	Operation Voltage	Operation Frequency	Remarks	Size
SR-2805R(IT)	3VDC	434MHz/868MHz	RF Wireless	120x80x29.1

Receiver

Part No.	Input Voltage	Output Current	Output Power	Remarks
SR-2501N	12-36VDC	4x5A	4x(60-180)W	Constant voltage
SR-2501NEA	12-36VDC	4x8A	4x(96-288)W	Constant voltage
SR-2502N	12-36VDC	4x350mA	4x(4.2-12.6)W	Constant current
SR-2503N	12-36VDC	4x700mA	4x(8.4-25.2)W	Constant current
SR-2501NS	12-36VDC	1x8A	1x(96-288)W	Constant voltage
SR-2502NS	12-36VDC	1x350mA	1x(4.2-12.6)W	Constant current
SR-2503NS	12-36VDC	1x700mA	1x(8.4-25.2)W	Constant current

Installation

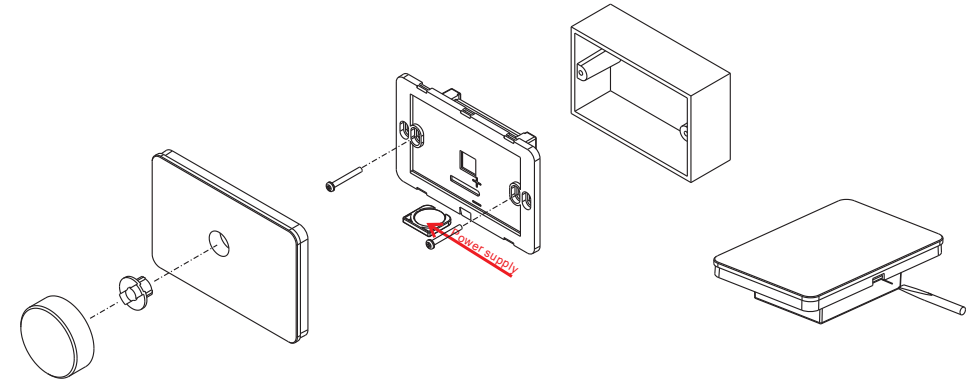

Wiring diagram

1)Receiver Connection Diagram for Single Unit

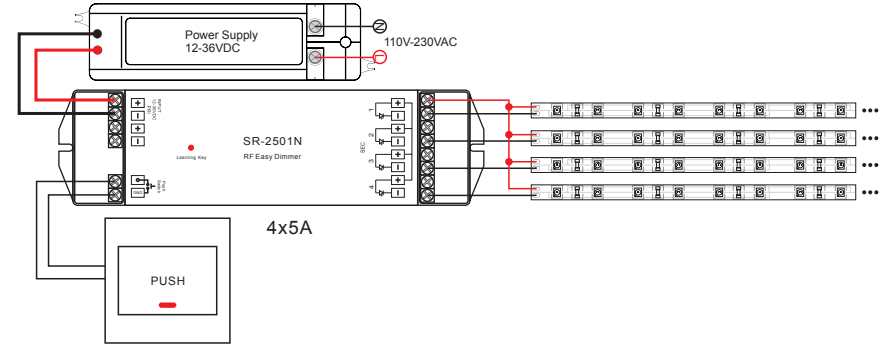

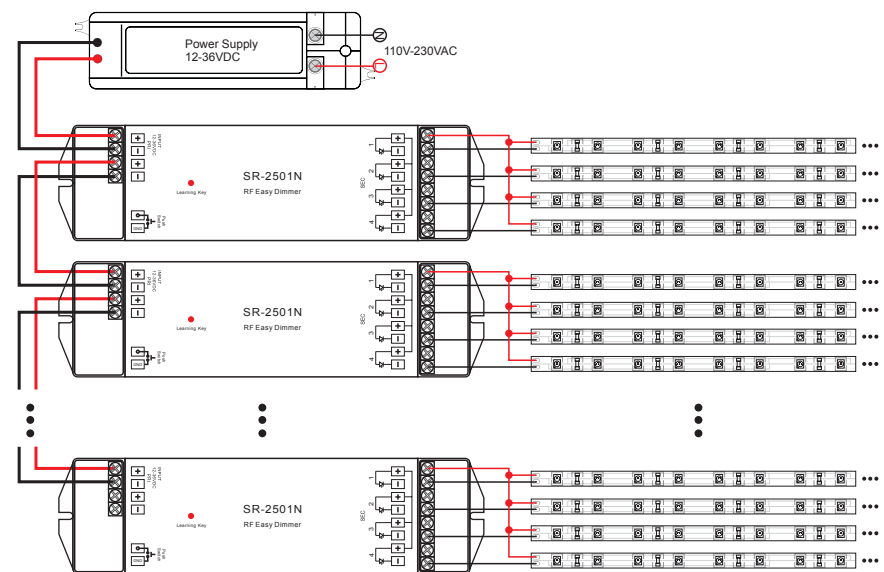

2)Receiver Connection Diagram for Multiple Units



Operation

Please pair remote and receiver, after finishing connecting receivers with LED lights correctly, base on diagram above.

1. Press shortly the learning Key ● on the receiver, then push the rotary button . Once successfully learn, the LED lights will blink on the receiver. Do the same for the other receivers if you use them, you can add as many optional receivers as you want.
2. Short push rotary button  to switch ON/OFF
Adjust dim brightness by the rotary button from left to right 0.1-100%
Adjust dim brightness by the rotary button from right to left 100-0.1%

Safety & Warnings

- 1) The product shall be installed and serviced by a qualified person.
- 2) IP20. Please avoid the sun and rain. When installed outdoors, please ensure it is mounted in a water proof enclosure.
- 3) Always be sure to mount this unit in an area with proper ventilation to avoid overheating.
- 4) Please check if the output voltage of any LED power supplies used comply with the working voltage of the product.
- 5) Never connect any cables while power is on and always assure correct connections to avoid short circuits before switching on.
- 6) Please ensure that the cable is secured tightly in the connector
- 7) For update information please consult your supplier.

Warranty Agreement

- 1) We provide lifelong technical assistance with this product:
 - 3-year warranty. We print date on every products, for example : 1125 means year 2011, week 25. The warranty is for free repair or replacement and covers manufacturing faults only.
 - For faults beyond the 3-year warranty we reserve the right to charge for time and parts.
- 2) Limited Warranty
 - Any defects caused by wrong operation.
 - Any damages caused by unauthorized removal, maintenance, modifying, incorrect connection and replacement of chips.
 - Any damages due to transportation, vibration etc. after purchase.
 - Any damages caused by earthquake, fire, lightning, pollution and abnormal voltage.
 - Any damages caused by negligence, inappropriate storing at high temperatures and humidity or near harmful chemicals.
 - Product has been updated
- 3) Repair or replacement as provided under this warranty is the exclusive remedy to the customer.