

Casambi 36W 2CH NFC Enabled LED Driver(Constant Current)

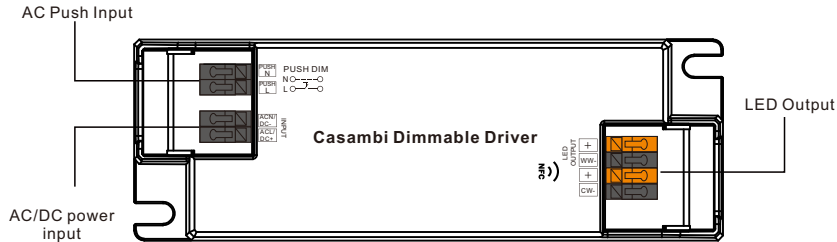

Important: Read All Instructions Prior to Installation

Function introduction



Product Data

Output	LED Channel	2
	DC Voltage	6-54V, Max. 60V
	Current	350-1050mA via NFC tool; Min.current gear lower to 0.1mA, default 800mA
	Current Accuracy	±3% (±1% @ Certain full load) @ full load
	Rated Power	Max. 36W
Input	Voltage Range	220-240VAC/220-240VDC
	Absolute Voltage Range	196-264VAC/196-264VDC
	Frequency Range	0/50/60Hz
	Power Factor (Typ.)	> 0.95 @ 230VAC Full load*
	Total Harmonic Distortion	THD ≤ 14% (@ full load / 230VAC)*
	Efficiency (Typ.)	> 86% @ 230VAC full load*
	AC Current (Typ.)	0.25A Max.
	Inrush Current (Typ.)	Max. 8.56A at 230VAC; 88µs duration
	Leakage Current	< 5mA/230VAC
Control	Anti Surge	L-N:2KV
	Dimming Interface	Casambi
	Dimming Range	0.01%-100% @ Max current
	Dimming Method	Amplitude/CCR dimming
	Dimming Curve	Linear/ Logarithmic optional

Protection	Short Circuit	Yes, remove the fault conditions and re-power the device.
	Over Current	Yes, remove the fault conditions and re-power the device.
	Over Temperature	Yes, remove the fault conditions and re-power the device.
Environment	Working Temp.	-25°C ~ +45°C
	Max. Case Temp.	Tc=85°C
	Working Humidity	10% ~ 95% RH non-condensing
	Storage Temp. & Humidity	-40°C ~ +80°C, 10% ~ 95% RH
Safety & EMC	Safety Standards	EN61347-1, EN61347-2-13, GB/T 19510.1-2023, GB/T 19510.213-2023
	Withstand Voltage	I/P-O/P: 3.75KVAC
	Isolation Resistance	I/P-O/P: 100M Ohms / 500VDC / 25°C / 70% RH
	EMC Emission	EN55015, EN61000-3-2, EN61000-3-3, GB 17625.1-2022, GB/T 17743-2021
	EMC Immunity	EN61547, EN61000-4-2,3,4,5,6,8,11
Others	MTBF	191350H, MIL-HDBK-217F @ 230VAC full load and 25°C ambient temperature
	Dimension	145x45x28mm (L*W*H)
	Warranty	5 Years

*: PF/THD/Eff shall be different per different testing setup and equipment.

- Casambi dimmable LED driver, works with Casambi network
- 2 channels dimmable LED driver. Max. output power 36W
- 350-1050mA current selectable via NFC program tool. Min.current gear lower to 0.1mA
- Class II power supply, full isolated plastic case
- High power factor and efficiency
- ON/OFF, Dimming and Tunable White control
- Amplitude/CCR dimming, smooth and deep dimming
- IP20 rating, suitable for indoor LED lighting applications
- 5 years warranty

Safety & Warnings

- DO NOT install with power applied to the device.
- DO NOT expose the device to moisture.

Operation

Configuration via NFC tool

Note:

- 1) Please do not power on the device during the whole programming process.
- 2) Please make sure your phone has NFC function and enable it.
- 3) If you can't download the app, please contact us.

Step 1: Install SR NFC Tool app on your phone (search SR NFC Tool from Apple Store or Google Play), and add the device following the app instructions.

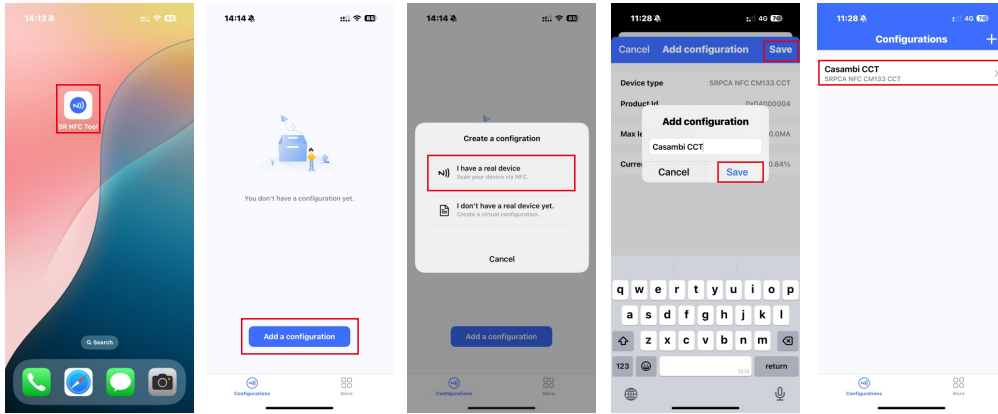

Step 3: After setting, write all configurations to the device.

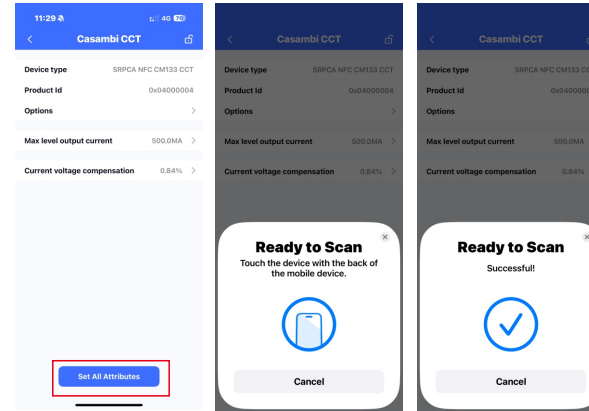

Step 2: Unlock the device and set the wanted parameters.

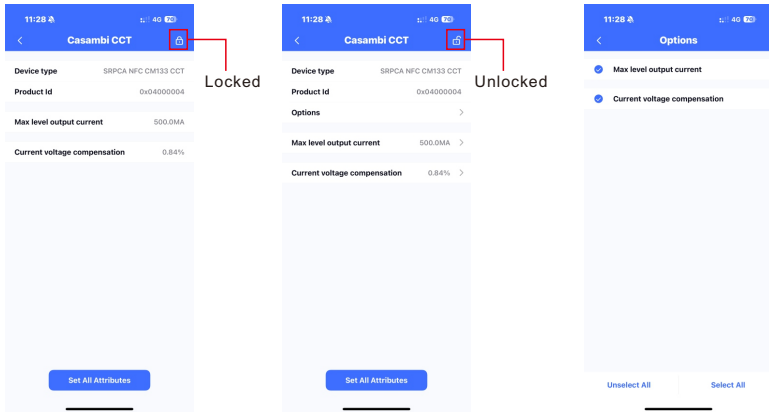

Parameters explained:

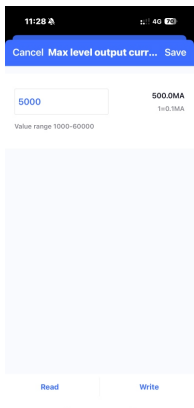

Target Current Setting:
0.1 mA adjustment for each current gear.

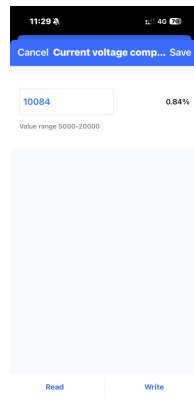

Current Compensation:
It is realized by setting different levels of current compensation for NFC drivers in different power segments and different currents of the driver.

It is a method to realize fine lighting control for most constant-current luminaries in the market (such as downlight, spotlight, panel light, etc).

Wiring Diagram

Application 1 (Without PUSH)

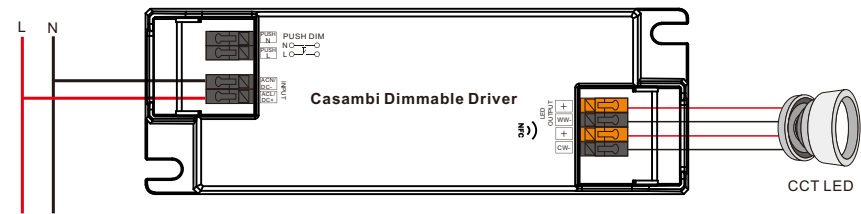

Note: Available with 3-wire CCT luminaries as well

Application 2 (With PUSH)

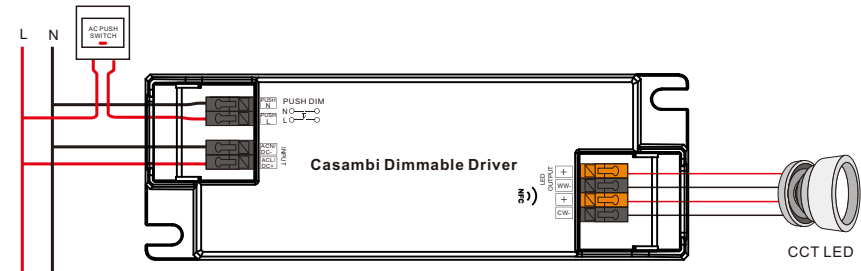

Note: Available with 3-wire CCT luminaries as well

Push Dim

- 1) Short press to switch on or off.
- 2) Long press to dim up or dim down.

Product Dimension

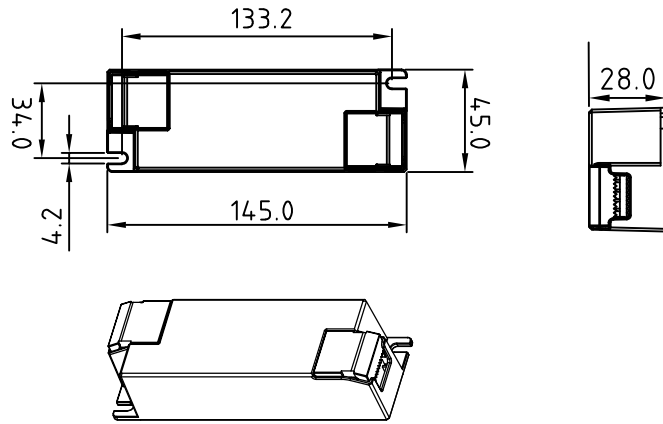

Operating window

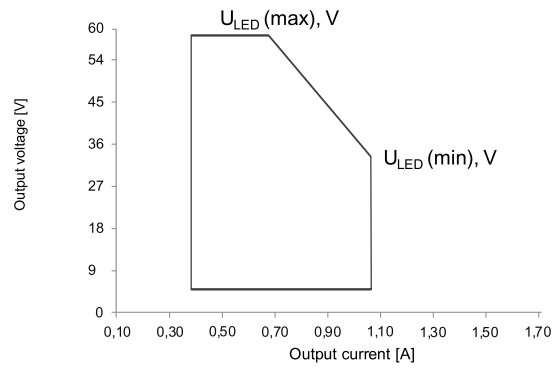

Dimming Curve

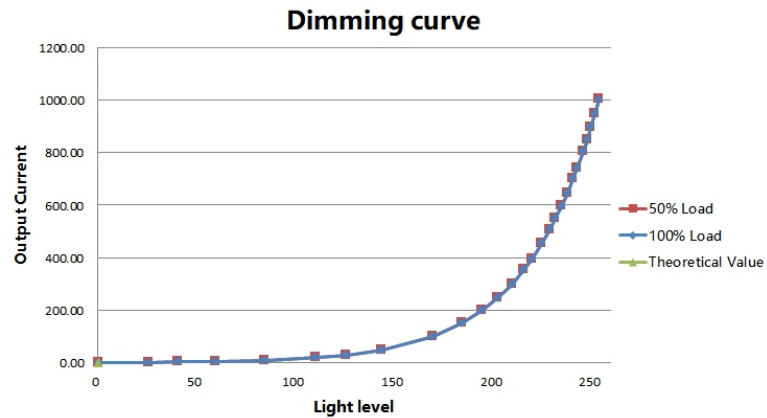

Driver Performance

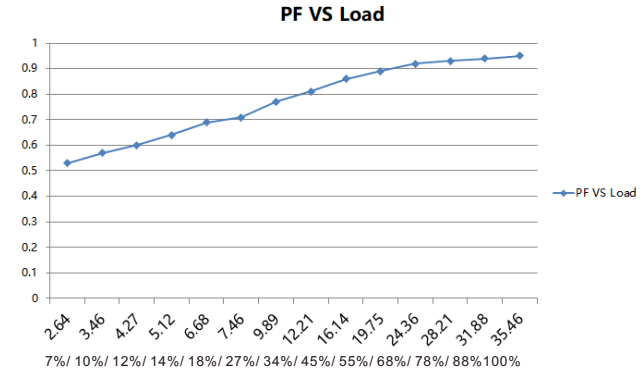

Note: Test data under 800mA gear

Driver Performance

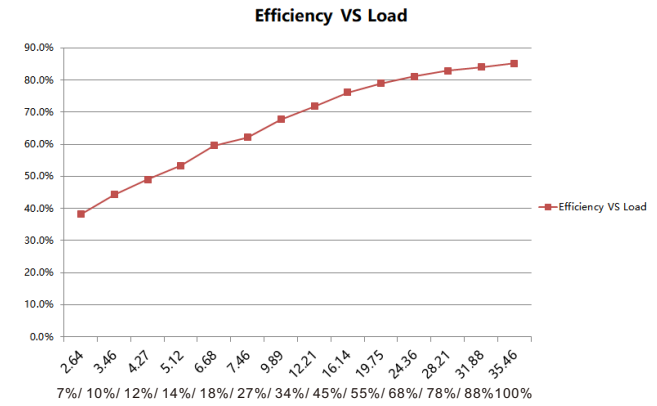

Note: Test data under 800mA gear

Driver Performance

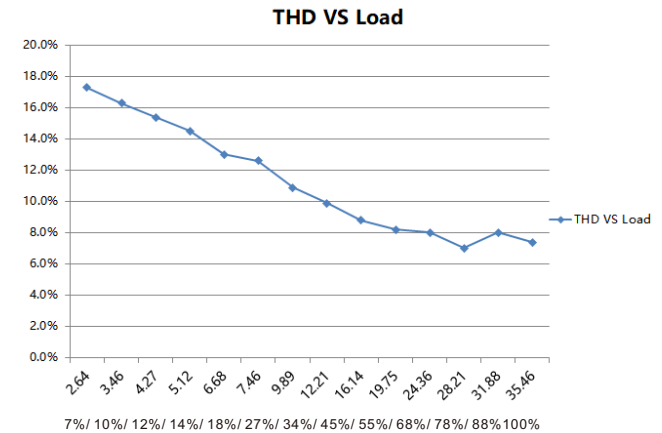

Note: Test data under 800mA gear

Expected Lifetime

Module Number	Output current	Ta	30 °C	40 °C	45 °C	...
SRP-CA9105N-36CC350-1050	350 – 1050 mA	Tc	50 °C	60 °C	66 °C	... 85 °C
SRP-CA9105N-36CCT350-1050	350 – 1050 mA	Lifetime	> 100,000 h	> 100,000 h	> 100,000 h	> 40,000 h

The LED driver is designed for a lifetime stated above under reference conditions.
The relation of tc to ta temperature depends also on the luminaire design.

MCB Load Quantity

Module Number	Ipeak	Twidth	Max. quantity of LED Driver per MCB														
			B10	B13	B16	B20	B25	C10	C13	C16	C20	C25	D10	D13	D16	D20	D25
SRP-CA9105N-36CC350-1050	8.56A	88µs	17	22	28	35	43	28	36	44	56	70	32	41	51	64	80
SRP-CA9105N-36CCT350-1050	8.56A	88µs	17	22	28	35	43	28	36	44	56	70	32	41	51	64	80

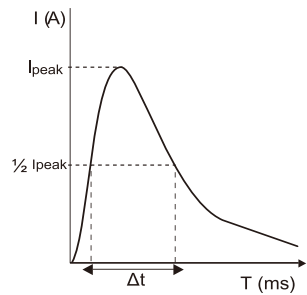

Note:

1. Those MCB parameters are based on ABB S200 series circuit breakers.
2. For different brands and models of miniature circuit breakers, the quantity of drivers will have difference.
3. Please do not exceed the above-mentioned quantity during on-site installation, and the specific load quantity shall be subject to on-site installation.
4. When the installation environment temperature of MCBs exceeds 30°C or when multiple MCBs are installed side by side, the number of mounted drives will be reduced, which requires recalculation.
5. Type C MCB's are strongly recommended to use with LED lighting

Quick Connector Box (Optional for Order)

SRP-Loopbox-01

Loop in & Loop Out design

1x DALI Loop in 1x AC Loop in
1x DALI Loop out 1x AC Loop out

Wiring capability:

0.5-2.5mm²(AWG 14-20)

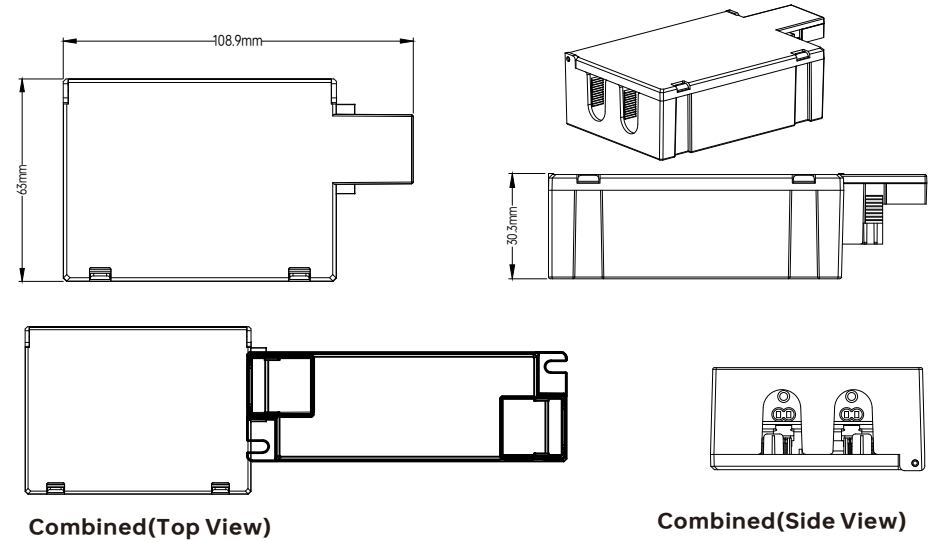

Note: Because the height of the 36W enclosure is slightly lower than that of the Loop box (Due to its own compact design) , it may be necessary to add a gasket on the plane (to maintain balance), not necessarily depending on site conditions.

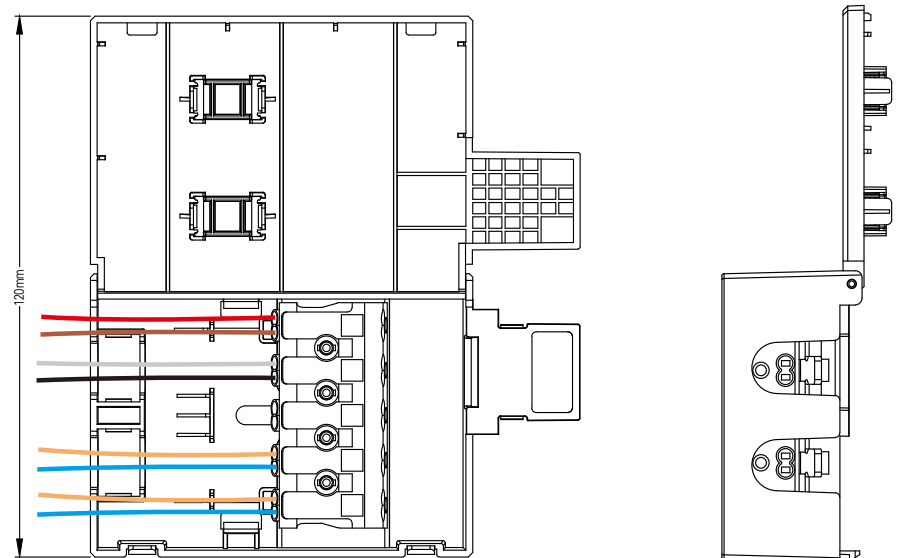

Quick Connector Box (Optional for Order)

SRP-Loopbox-02

Plug & Play design (Wago Terminal)

Wiring capability:
0.5-2.5mm²(AWG 14-20)

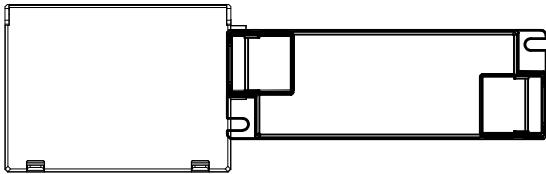
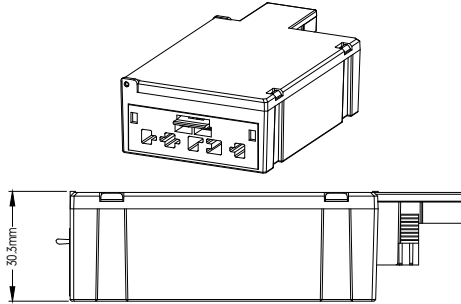
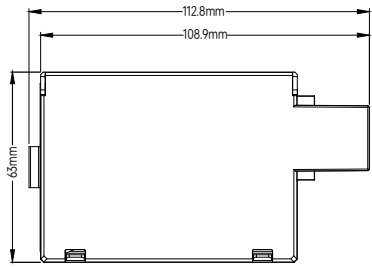

Combined(Top View)

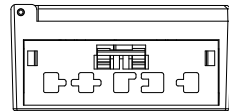

Combined(Side View)

Note: Because the height of the 36W enclosure is slightly lower than that of the Loop box (Due to its own compact design) , it may be necessary to add a gasket on the plane (to maintain balance), not necessarily depending on site conditions.

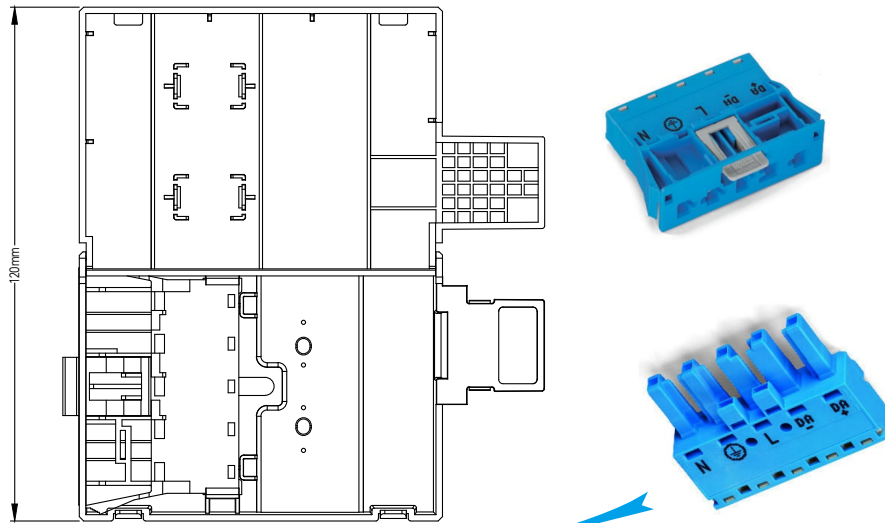

Mated with [Wago 770-1105/022-000](http://www.wago.com/770-1105/022-000)

<http://www.wago.com/770-1105/022-000>