

# RF+Bluetooth Micro Smart Dimmer

70200054



**Important:** Read All Instructions Prior to Installation

## Function introduction

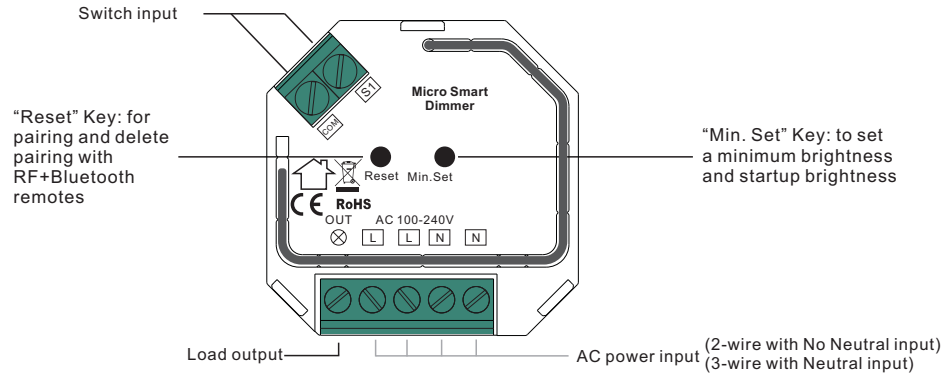

## Product Data

Radio Frequency	2.4GHz
Input Voltage	AC100-240V
Output Voltage	AC100-240V
Output Current	1.8A max.
Operating temperature	0 to 40°C
Relative humidity	8% to 80%
Dimensions	45.5x45x20.3mm

Compatible Load Types			
Load Symbol	Load Type	Maximum Load	Remarks
	Dimmable LED lamps	200W @ 230V 100W @ 110V	Due to variety of LED lamp designs, maximum number of LED lamps is further dependent on power factor result when connected to dimmer.
	Dimmable LED drivers	200W @ 230V 100W @ 110V	Maximum permitted number of drivers is 200W divided by driver nameplate power rating.
	Incandescent lighting, HV Halogen lamps	400W @ 230V 200W @ 110V	
	Low voltage halogen lighting with electronic transformers	200W @ 230V 100W @ 110V	

## Safety & Warnings

- DO NOT install with power applied to device.
- DO NOT expose the device to moisture.

## Main Features:

- RF+Bluetooth micro smart dimmer
- Can operate under two-wire connection with no neutral lead or three-wire connection with neutral lead
- Both leading edge version and trailing edge version are available for choosing, factory default is trailing edge
- Enables to control ON/OFF and light intensity of connected load
- Controlled through both smart App and remote controls, no gateway required
- Easy & quick pairing to the smart App by simply pushing the reset button, supports voice control through Alexa
- Mesh network, much longer control distance, transmits received signal to neighbor devices
- Up to 30m transmission distance between every two neighbor devices
- Encrypted two-way communication, quick status feedback, safe & reliable data transmission
- Compatible with universal RF+Bluetooth remotes, each LED controller can pair to max. 8 remotes
- Cloud control is available for remote access, works with Amazon Alexa and Google Home
- Implemented algorithm of smart light source detection
- Auto-adjustment of the appropriate control mode to connected load
- Soft start function
- Memory of the last lighting level settings
- Works with various types of switches – momentary, toggle, three-way, etc.
- To be installed in wall switch boxes of dimensions allowing for installation
- The Bypass is an extension unit.

## As a dimmer it operates under the following loads:

- Conventional incandescent and HV halogen light sources
- ELV halogen lamps and dimmable LED bulbs (with electronic transformers)
- MLV halogen lamps (with ferromagnetic transformers)
- Dimmable LED bulbs
- Dimmable compact fluorescent CFL tube lamps
- Supported dimmable light sources (power factor > 0.5) with minimal power of 3VA using the Bypass (depending on the type of load)

## Trailing edge or leading edge dimming mode can be preset by factory setting to control following types of loads:

- "Trailing edge" for resistive loads
- "Trailing edge" for capacitive loads
- "Leading edge" for inductive loads

**Note: factory default version is trailing edge.**

## Operation

### Pair/delete the pairing with RF+Bluetooth remote

1. Do wiring according to connection diagram.
2. Pair LED controller with RF+Bluetooth remote: please refer to the instruction of the remote that you would like to pair with.
3. Delete the pairing:
  - (1) Wire up the LED controller correctly, power on.
  - (2) Press and hold down the "Reset" button on the controller for over 3 seconds (or reset power of the device 8 times continuously if the button is not accessible to factory reset the device) until the connected light flashes, which means well deleted.

Note: factory resetting will restore all configured parameters of the device on the APP to factory default setting.

## Pair with smart APP

1. Do wiring according to connection diagram.
2. Download EasyThings APP from IOS APP Store or Android Google Play to your smart phone or tablet by searching "EasyThings". (As shown in **Figure 1**)
3. Enable Bluetooth on your smart phone or tablet. (As shown in **Figure 2**)



Figure 1

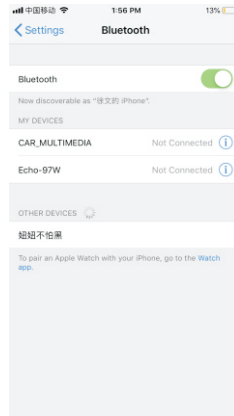

Figure 2

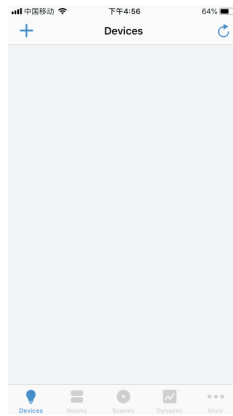

Figure 3

4. Run Easythings APP, tap add button " + " on the APP to add device, then choose "Discover devices" to discover device, then **short press the "Reset" button on the dimmer twice (or reset power of the dimmer twice continuously)** to set the device into pairing to APP mode. (As shown in **Figure 3 & Figure 4 & Figure 5**)

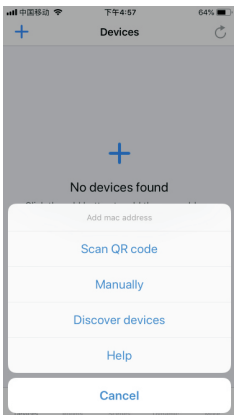

Figure 4

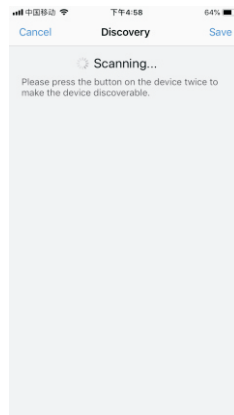

Figure 5

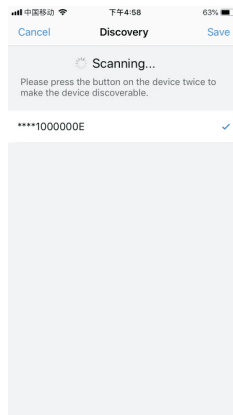

Figure 6

**Note:** multiple dimmers can be discovered by the APP at the same time.

5. Once the device/device are discovered, tick the device/devices and tap "Save" button, the device/devices will be added successfully. (as shown in **Figure 6**)

## Minimum and Startup Brightness Setting Button

Press and hold down the button for 3 seconds to set minimum brightness: when current brightness value is 1%-50%, it will be set as minimum brightness. When current brightness value is 100%, previously set minimum brightness will be deleted. Once a minimum brightness is set, the connected load can not be dimmed below this level.



Short press the button twice to set startup brightness: when current brightness value is 1%-50%, it will be set as startup brightness. When current brightness value is 0%, previously set startup brightness will be deleted.

**Note:** startup brightness setting function is to avoid the phenomenon that some dimmable LED drivers can not be turned on after dimmed to a low level and turned off. Once setting a startup brightness, if the startup brightness is higher than dimmed level before turned off, the driver will first go to the startup brightness after turned on then drop down to the dimmed level. If the startup brightness is lower than the dimmed level before turned off, the driver will directly go to the dimmed level after turned on .

## Controlled by a push switch:

Once connected with a push switch, click the push switch to switch ON/OFF, press and hold down it to increase/decrease light intensity between 1% to 100%.

## Compatible load types and recommended values of power for supported loads:

Supported load types		100-240V~	
	<b>Resistive loads</b> Conventional incandescent and halogen light sources	20-400W @ 230V 20-200W @ 110V	
	<b>Capacitive loads</b> Fluorescent tube lamp (compact / with electronic ballast), electronic transformer, LED	Using Bypass: 3-200W @ 230V 3-100W @ 110V	No Bypass Used: 20-200W @ 230V 20-100W @ 110V
	<b>Inductive loads</b> Ferromagnetic transformers	20-200W @ 230V 20-100W @ 110V	

## Wiring Diagram

### Notes for the diagrams:

L - terminal for live lead

N - terminal for neutral lead

Out - output terminal of the dimmer (controlling connected light source)

S1 - terminal for switch (has the option of entering the device in inclusion/exclusion mode)

COM - terminal for grounding to the switch connected to the dimmer

## Product Dimension

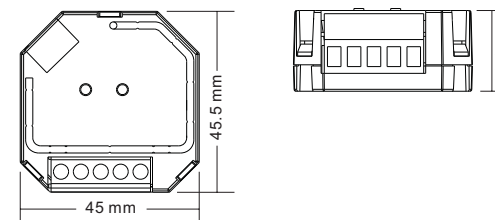

**Supported external switch types (should be configured by factory setting):**

- 1) Push switch (default factory setting)
- 2) Normal On/Off switch (should be configured by factory setting upon request)

**(1) 2-Wire Connection With No Neutral Lead**

**With PUSH LV**

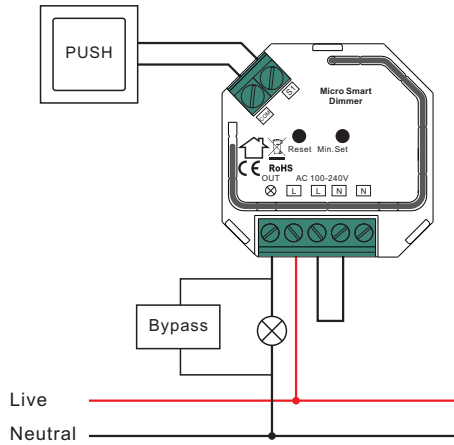

**With PUSH**

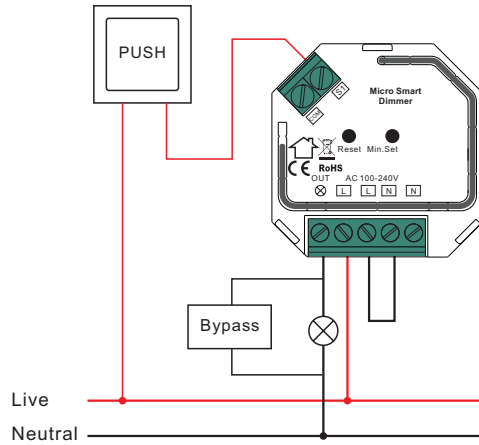

**NOTE:** Switch connected to the S1 terminal activates the basic functionality of the dimmer (turning the light on/off, dimming).

The Bypass is a device designed to work with the micro smart dimmer. It should be used in case of connecting LED bulbs or energy saving compact fluorescent lamps. The Bypass prevents flickering of the LED lights and glowing of the turned off compact fluorescent lamps. In the case of 2-wire connection, the Bypass allows to reduce minimum power of load required by the dimmer for correct operation. The Bypass provides powering of the dimmer in case of controlling the low loads of minimum power down to 3W (for  $\cos\phi > 0.5$ ).

**(2) 3-Wire Connection With Neutral Lead**

**With PUSH LV**

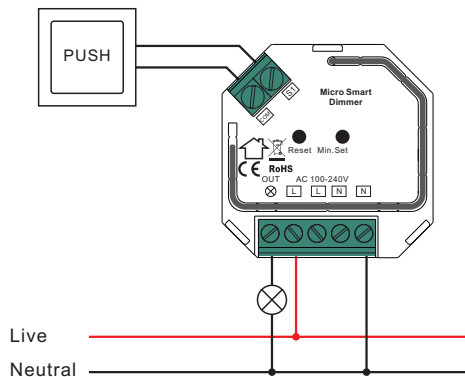

**With PUSH**

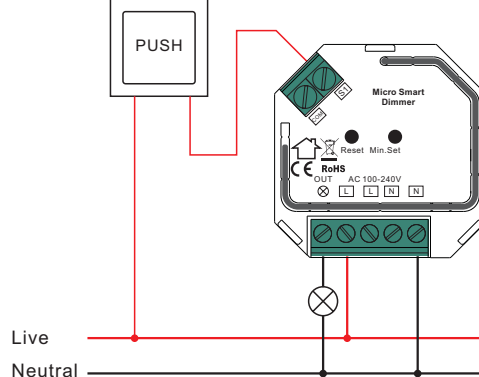

**NOTE:** Switch connected to the S1 terminal activates the basic functionality of the dimmer (turning the light on/off, dimming).

**(3) Multiple Momentary or Push Switches Connection**

**With PUSH LV**

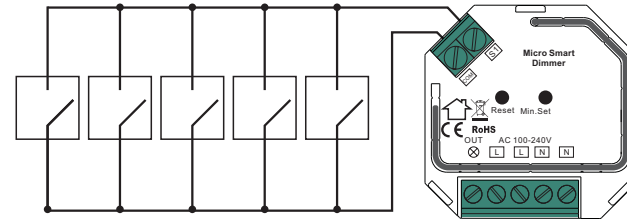

**With PUSH**

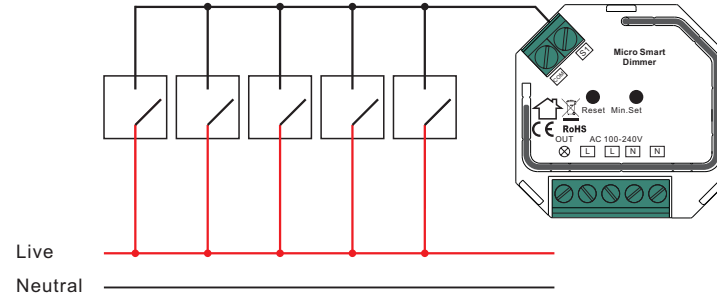

This phase dimmer adopts leading edge dimming (forward phase control) or trailing edge dimming (reverse phase control), two versions are available for choosing, factory default version is trailing edge. Please make sure the connected loads support the control type you choose. Please refer to the user manual of the load or consult the supplier of the load.