

Push Compatible RF+Bluetooth Knob Smart Dimmer 09.SB2835RACS.04736

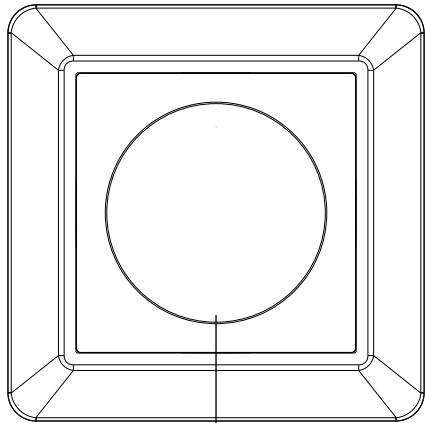

Important: Read All Instructions Prior to Installation

Function introduction



Rotary knob, short press to turn on/off, rotate clockwise to increase brightness, rotate counterclockwise to decrease brightness

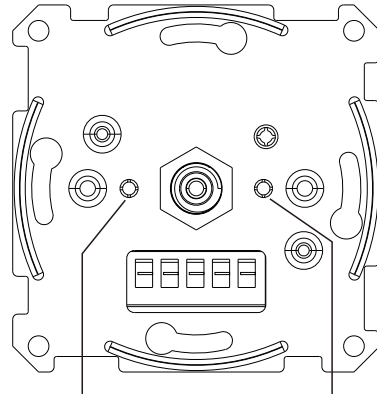

"Min. Set" Key: for minimum brightness and startup brightness setting

"Reset" Key: for pairing and delete pairing with RF+Bluetooth remotes

Front side

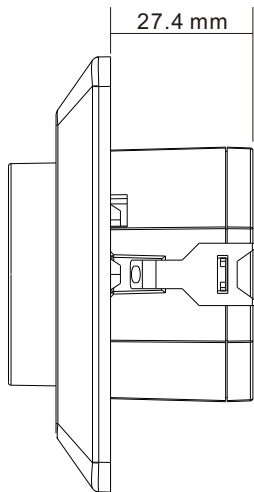

27.4 mm

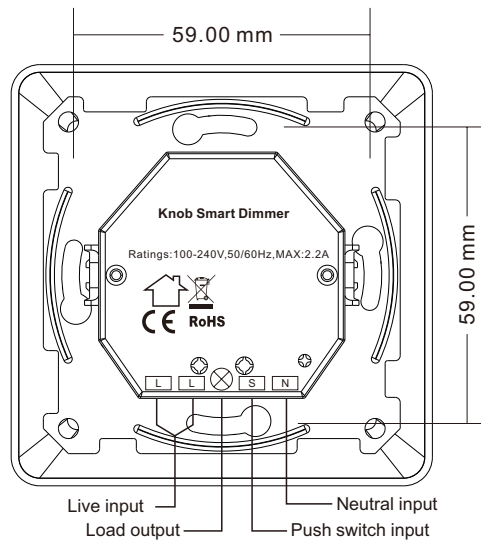

59.00 mm

59.00 mm

Live input
Load output
Neutral input
Push switch input

Product Data

Input Voltage	Output Voltage	Output Current	Size(LxWxH)
100-240VAC	100-240VAC	2.2A max	83.8x83.8x47.1mm

Compatible Load Types

Load Symbol	Load Type	Maximum Load	Remarks
	Dimmable LED lamps	250W @ 230V 125W @ 110V	Due to variety of LED lamp designs, maximum number of LED lamps is further dependent on power factor result when connected to dimmer.
	Dimmable LED drivers	250W @ 230V 125W @ 110V	Maximum permitted number of drivers is 250W divided by driver nameplate power rating.
	Incandescent lighting, HV Halogen lamps	500W @ 230V 250W @ 110V	
	Low voltage halogen lighting with electronic transformers	250W @ 230V 125W @ 110V	

Safety & Warnings

- DO NOT install with power applied to device.
- DO NOT expose the device to moisture.

- RF+Bluetooth rotary smart dimmer
- 100-240VAC wide input and output voltage, can work under no neutral wiring and with neutral wiring, self-adaptive
- Supports resistive loads, capacitive loads or inductive loads
- Enables to set minimum brightness and startup brightness
- 1 channel output, up to 500W
- Both leading edge version and trailing edge versions are available for choosing, factory default is trailing edge
- Enables to control ON/OFF and light intensity of connected load
- Controlled through both smart App and remote controls, no gateway required
- Easy & quick pairing to the smart App by simply pushing the reset button, supports voice control through Alexa
- Mesh network, much longer control distance, transmits received signal to neighbor devices
- Up to 30m transmission distance between every two neighbor devices
- Encrypted two-way communication, quick status feedback, safe & reliable data transmission
- Compatible with universal RF+Bluetooth remotes, each LED controller can pair to max. 8 remotes
- Cloud control is available for remote access, works with Amazon Alexa and Google Home
- With push switch input, can be controlled by universal AC push switches
- Standard size, can be compatible with existing EU standard frames, and installed into standard size wall box
- Radio Frequency : 2.4GHz
- Waterproof grade: IP20

Main Features:

- Can operate under two-wire connection with no neutral lead or three-wire connection with neutral lead
- Advanced microprocessor control
- Implemented algorithm of smart light source detection
- Soft start function
- Innovative minimum dimming level and startup brightness setting functions
- The Bypass is an extension unit

As a dimmer it operates under the following loads:

- Conventional incandescent and HV halogen light sources
- ELV halogen lamps and dimmable LED bulbs (with electronic transformers)
- MLV halogen lamps (with ferromagnetic transformers)
- Dimmable LED bulbs
- Dimmable compact fluorescent CFL tube lamps
- Supported dimmable light sources (power factor > 0.5) with minimal power of 3VA using the Bypass (depending on the type of load)

Trailing edge or leading edge dimming mode can be preset by factory setting to control following types of loads:

- "Trailing edge" for resistive loads
- "Trailing edge" for capacitive loads
- "Leading edge" for inductive loads

Note: factory default version is trailing edge.

Operation

Pair/delete the pairing with RF+Bluetooth remote

1. Do wiring according to connection diagram.
2. Pair LED controller with RF+Bluetooth remote: please refer to the instruction of the remote that you would like to pair with.
3. Delete the pairing:
 - (1) Wire up the LED controller correctly, power on.
 - (2) Press and hold down the “Reset” button on the controller for over 3 seconds (or reset power of the device 8 times continuously if the button is not accessible to factory reset the device) until the connected light flashes, which means well deleted.

Note: factory resetting will restore all configured parameters of the device on the APP to factory default setting.

Pair with smart APP

1. Do wiring according to connection diagram.
2. Download EasyThings APP from IOS APP Store or Android Google Play to your smart phone or tablet by searching “EasyThings”. (As shown in **Figure 1**)
3. Enable Bluetooth on your smart phone or tablet. (As shown in **Figure 2**)

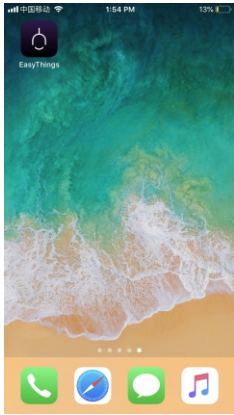

Figure 1

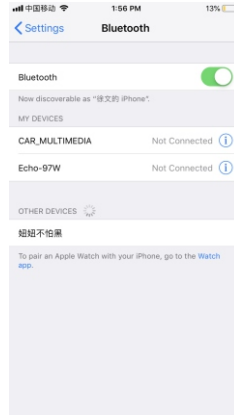

Figure 2

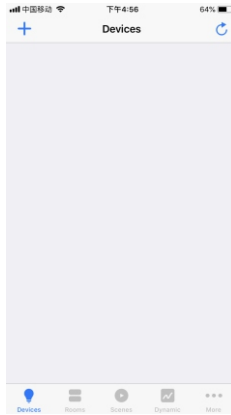

Figure 3

4. Run Easythings APP, tap add button “+” on the APP to add device, then choose “Discover devices” to discover device, then **short press the “Reset” button on the dimmer twice (or reset power of the dimmer twice continuously)** to set the device into pairing to APP mode. (As shown in **Figure 3 & Figure 4 & Figure 5**)

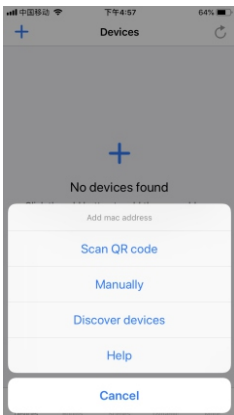

Figure 4

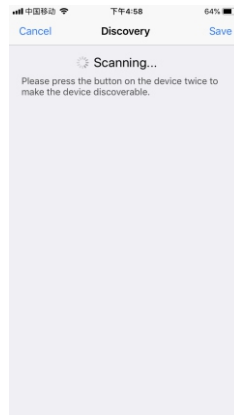

Figure 5

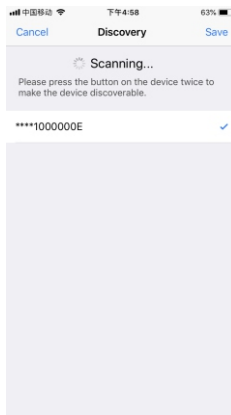

Figure 6

Note: multiple dimmers can be discovered by the APP at the same time.

5. Once the device/device(s) are discovered, tick the device/device(s) and tap “Save” button, the device/device(s) will be added successfully. (as shown in **Figure 6**)

Minimum Brightness Setting

Set Minimum Brightness



Step 1: adjust the brightness of connected load to a desired level between 1%-50%.

Delete Minimum Brightness



Step 1: adjust the brightness of connected load to 100%.

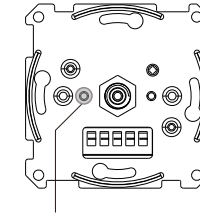

Step 2: press and hold down “Min. set” key for 3 seconds until connected load blinks to set the brightness adjusted in step 1 as minimum brightness, then the load can not be dimmed below this level.

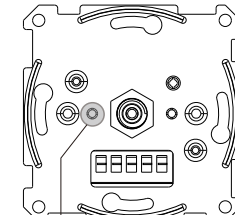

Step 2: press and hold down “Min. set” key for 3 seconds until connected load blinks to delete the previously set minimum brightness.

Startup Brightness Setting

Set Startup Brightness



Step 1: adjust the brightness of connected load to a desired level between 1%-50%.

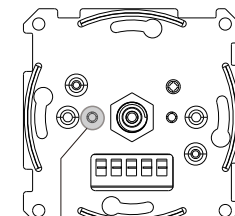

Step 2: double click “Min. set” key to set the brightness adjusted in step 1 as startup brightness, then the load will first go to startup brightness when turned on every time, then drop down to the brightness before last time turned off.

Note: startup brightness setting function is to avoid the phenomenon that some dimmable LED drivers can not be turned on after turned off at a very low brightness level. Once setting a startup brightness, if the startup brightness is higher than the brightness before turned off, the driver will first go to the startup brightness after turned on then drop down to the level before turned off. If the startup brightness is lower than the brightness before turned off, the driver will directly go to the brightness before turned off.

Delete Startup Brightness



Step 1: adjust the brightness of connected load to 0%.

Step 2: double click "Min. set" key to delete the previously set startup brightness.

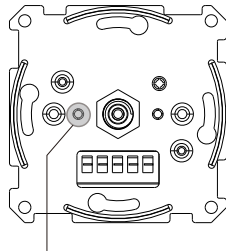

Controlled by a push switch:

Once connected with a push switch, click the push switch to switch ON/OFF, press and hold down it to increase/decrease light intensity between 1% to 100%.

Wiring Diagram

Notes for the diagrams:

L - terminal for live lead

N - terminal for neutral lead

⊗ - output terminal of the dimmer (controlling connected light source)

S - terminal for push switch

(1) 2-Wire Connection With No Neutral Lead

Single push switch wiring

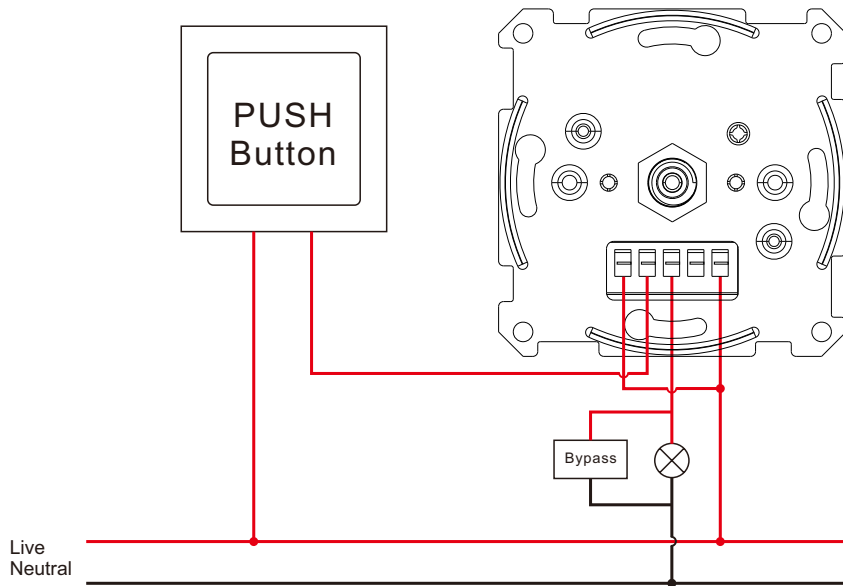

Multiple push switches wiring for multiple control points

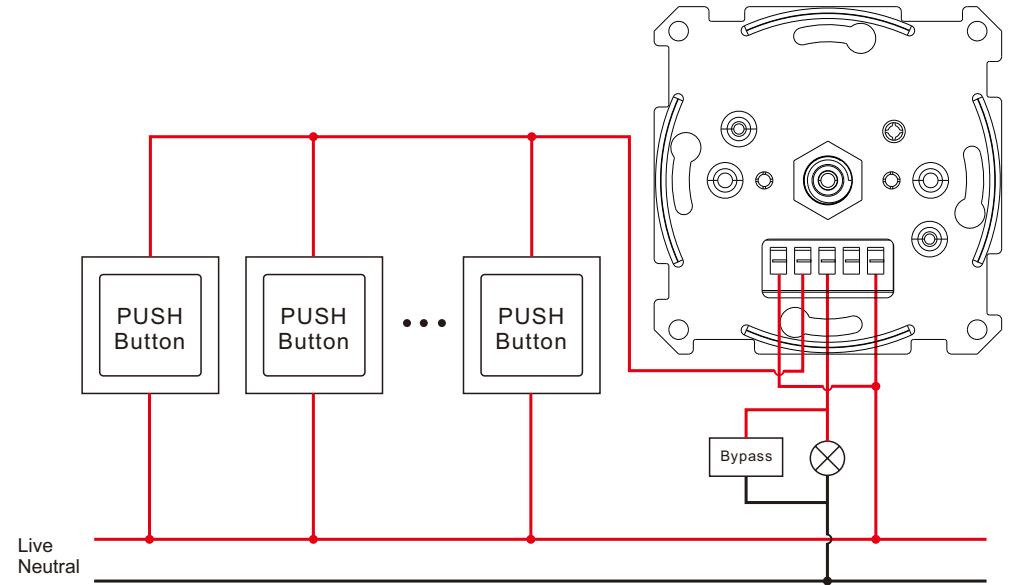

The Bypass is a device designed to work with the knob smart dimmer. It should be used in case of connecting LED bulbs or energy saving compact fluorescent lamps. The Bypass prevents flickering of the LED lights and glowing of the turned off compact fluorescent lamps. In the case of 2-wire connection, the Bypass allows to reduce minimum power of load required by the dimmer for correct operation. The Bypass provides powering of the dimmer in case of controlling the low loads of minimum power down to 3W (for $\cos\phi > 0.5$).

(2) 3-Wire Connection With Neutral Lead

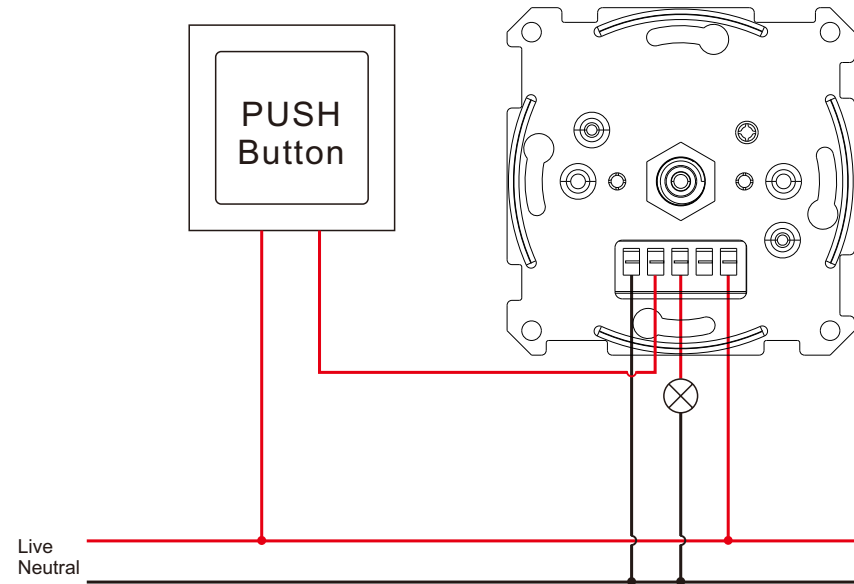

Single push switch wiring

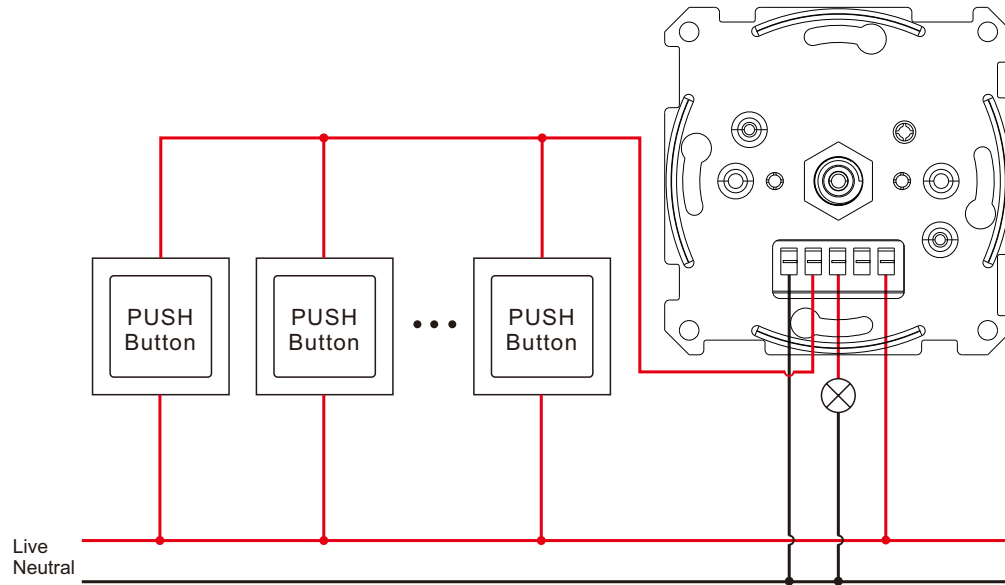

Multiple push switches wiring for multiple control points



Compatible load types and recommended values of power for supported loads:

Supported load types		100-240V~	
	Resistive loads Conventional incandescent and halogen light sources	20-500W @ 230V 20-250W @ 110V	
	Capacitive loads Fluorescent tube lamp (compact / with electronic ballast), electronic transformer, LED	Using Bypass: 3-250W @ 230V 3-125W @ 110V	No Bypass Used: 20-250W @ 230V 20-125W @ 110V
	Inductive loads Ferromagnetic transformers	20-250W @ 230V 20-125W @ 110V	

This phase dimmer adopts leading edge dimming (forward phase control) or trailing edge dimming (reverse phase control), two versions are available for choosing, factory default version is trailing edge. Please make sure the connected loads support the control type you choose. Please refer to the user manual of the load or consult the supplier of the load.

Installation

