

DIN Rail Ethernet (IP) DALI Gateway

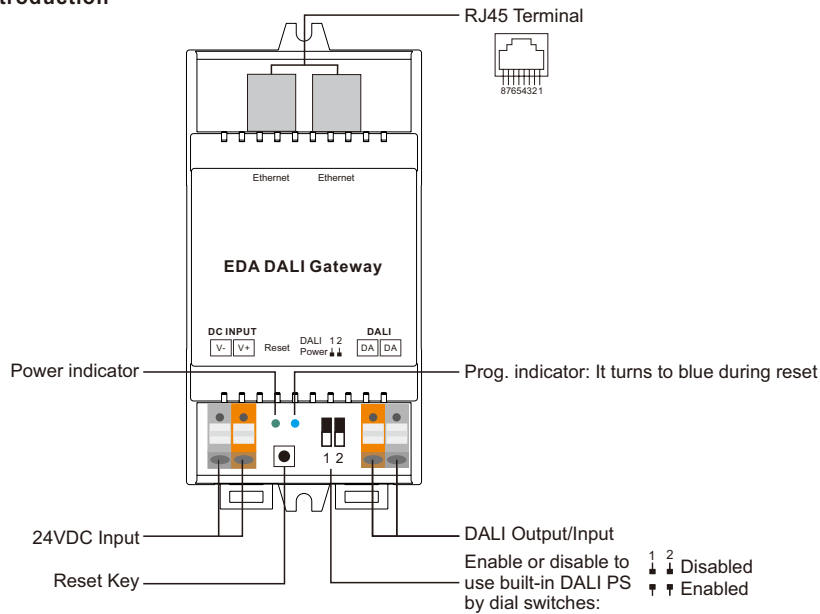

Important: Read All Instructions Prior to Installation

Function introduction



Test function:

Short press Reset Key to turn on all lights on the bus, press again to turn off.

Full brightness:

Double press Reset Key to set all lights on the bus to 100% brightness.

Static IP address:

Press and hold Reset Key for 5s to set the gateway to static IP address: 10.10.10.100

DHCP mode:

Short press Reset Key 10 times to set the gateway to DHCP IP address mode, the address will be assigned by router

Reset gateway:

Short press Reset Key 5 times, the blue indicator will turn on, then immediately press and hold Reset Key for 5s to reset the gateway to factory settings

Note: these operations above are base on the PC software version V2.0.11, and the firmware version V3.16. If the versions are below these, you need to update them first.

Product Data

While built-in DALI PS enabled

Input Voltage	Number of DALI Channel	Output Voltage	Output Current	Size(LxWxH)	Ambient Temperature
24VDC	1	12-22.5VDC	Guaranteed supply current: 230mA Max. supply current: 250mA	110x53x65mm	-20°C ~ +50°C

While built-in DALI PS disabled

Input Voltage	Number of DALI Channel	DALI Current Consumption	Size(LxWxH)	Ambient Temperature
24VDC	1	Max. 2mA	110x53x65mm	-20°C ~ +50°C

- Supports DT6, DT8 Tc, DT8 XY, DT8 RGBWA device types
- Supports addressing, grouping and scene configuration for max. 64 control gears (DALI-1 and DALI-2)
- Built-in 250mA DALI PS, no extra wiring required
- Easy connect to a network through Ethernet connection
- Easy & quick configuration through DALI Center PC application
- Built-in battery, built-in RTC, supports timer task configuration
- Can monitor DALI bus data
- Waterproof grade: Ip20
- 5 years warranty

Wiring Diagram

1) While built-in DALI PS enabled

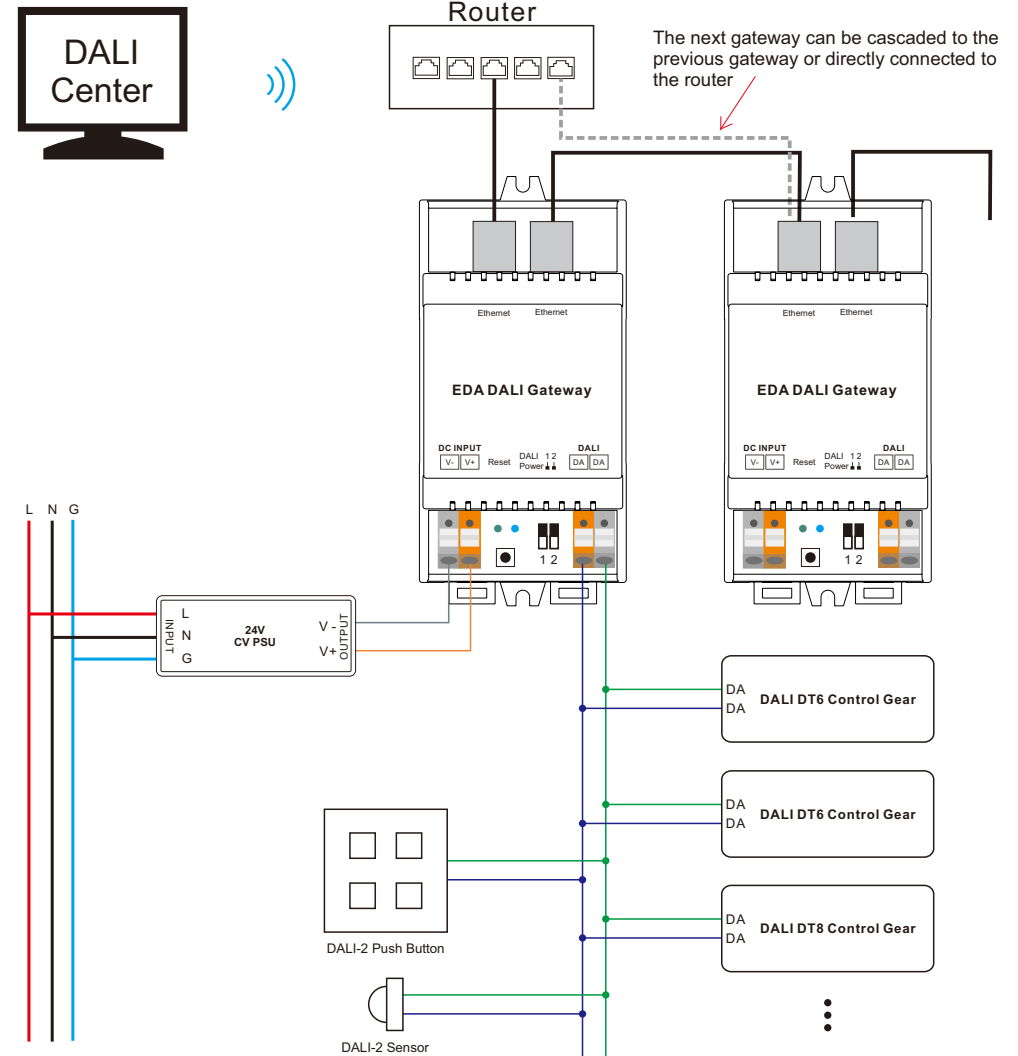

Note: Recommended no more than 8 sensors be installed on a single DALI bus.

The current at the moment of sensor trigger can reach up to 30mA. If too many sensors are installed on the same DALI bus, and several sensors are triggered simultaneously, the total power consumption may exceed the current limit of the DALI bus, which could lead to potential issues.

2) While built-in DALI PS disabled

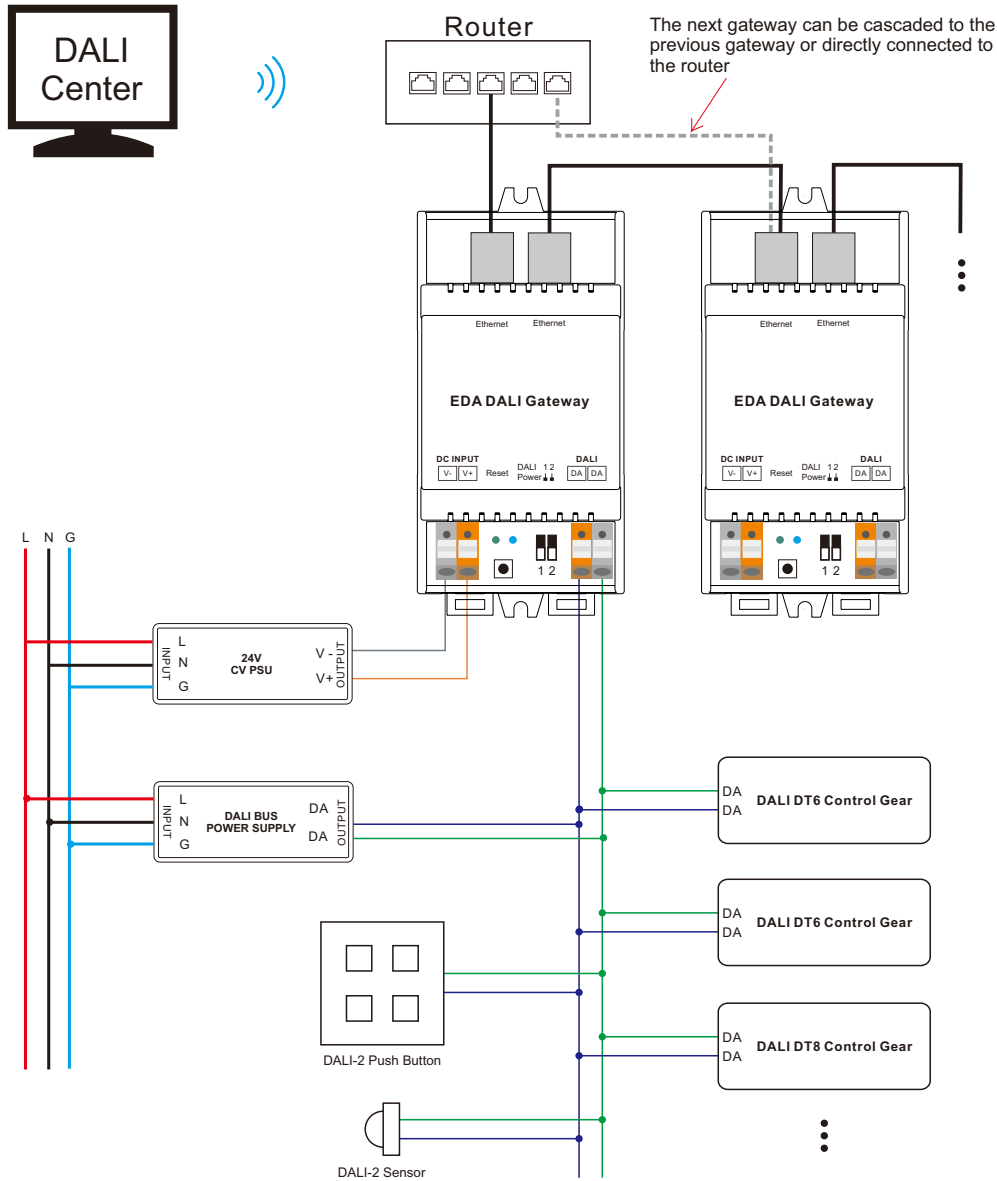

Note: When built-in DALI Bus PS is disabled, the number of following control gears depends on external DALI PS.

Operation

- 1) Do wiring according to the wiring diagram and power on the DALI system.
- 2) Pair the DALI gateway to the network and control it through the DALI Center.

Product Dimension

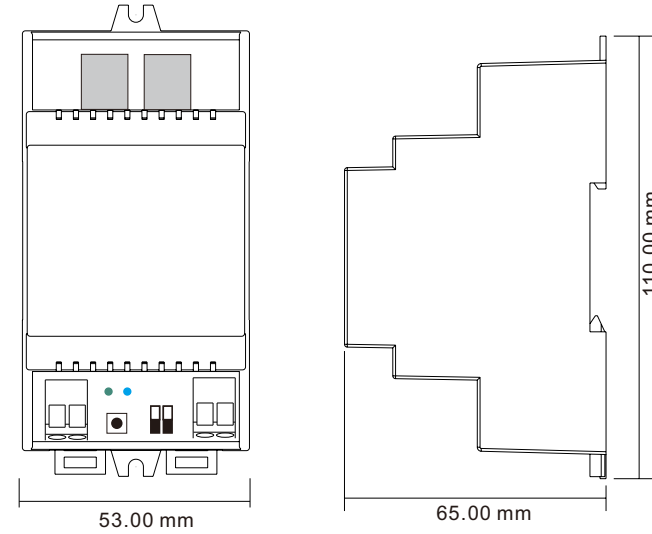

Tips

1. Working with Universal DALI-2 control gears
2. Better performance with SUNRICHER DALI devices

Download DALI Master PC Software

DALI Master PC software can be downloaded from the following links:
<https://www.sunricher.com/downloads>