

Z-Wave To DALI DT6 & DT8 4 in 1 Controller

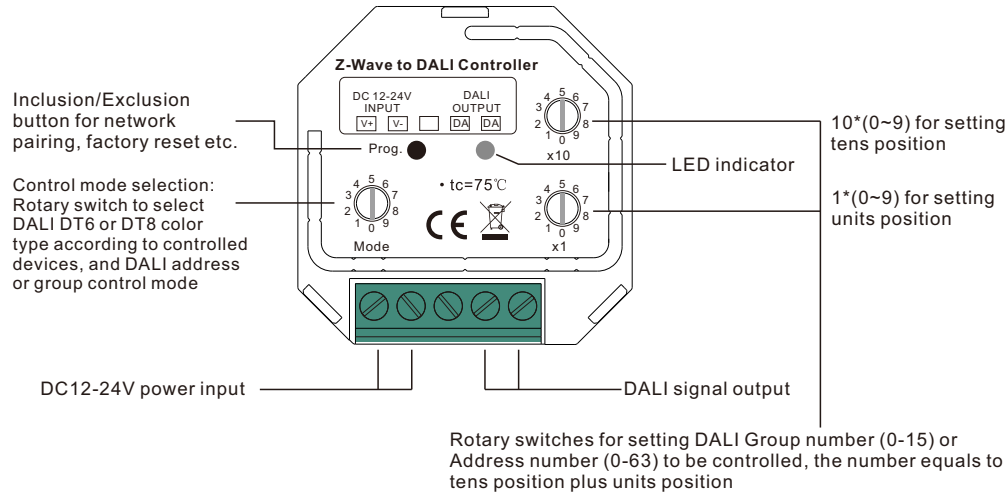

Important: Read All Instructions Prior to Installation
Function introduction



Product Data

Input signal	Z-Wave
Radio frequency	868.42 MHz (EU)/908.42 MHz (US)/921.42MHz (ANZ) /869.0 MHz (RU)
Output	DALI signal
Power Supply	12-24VDC
DALI Current Consumption	<4mA
Operating temperature	0-40°C
Relative humidity	8% to 80%
Dimensions(LxWxH)	45.5x45x20.3mm

- 4 in 1 Z-Wave to DALI DT6 & DT8 Controller based on Z-Wave plus
- Receives Z-Wave signal and outputs DALI signal to DALI line, 12-24VDC power supply
- Compatible with universal Z-Wave gateway controllers
- Supports association with Z-Wave remote controls and touch panels
- DALI current consumption less than 4mA
- Controlled DALI device type can be DT6 or DT8, device type selectable by rotary switch
- Controlled DT8 device color type: Tc, XY coordinates, RGBW selectable by rotary switch
- Enable to select Group control or Address control to DALI line by rotary switch
- Enable to control 1 DALI Group of devices or 1 DALI Address on DALI line
- Enable to control all devices on DALI line via broadcast

- Enable to select any DALI Group (0-15) or DALI Address (00-63) to control by rotary switches
- Each DALI line can install multiple controllers for multi control points
- Waterproof grade: IP20

Safety & Warnings

- DO NOT install with power applied to device.
- DO NOT expose the device to moisture.

Quick Start

How to install:

Step 1: power on the Z-Wave to DALI controller, the controlled DALI drivers will flash quickly for 6 seconds, triple press the "Inclusion/Exclusion" button, then go on step 2. If it is not, then terminate the operation, please refer to the part "Inclusion" of this manual to learn how to include the controller to Z-Wave network.

Step 2: activate inclusion mode on your Z-Wave controller.

Step 3: the Z-Wave to DALI controller is waiting to be included to Z-Wave network, the controlled DALI drivers stay solid on 3s to indicate successful inclusion.

Product Description

The Z-Wave to DALI controller is a Z-Wave device that is used to switch ON/OFF and adjust light intensity of DALI control gears on a DALI circuit and can be controlled by other Z-Wave devices. It can be included and operated in any Z-Wave network with other Z-Wave certified devices from other manufacturers and/or other applications. All non-battery operated nodes within the network will act as repeaters regardless of vendor to increase reliability of the network.

the device cannot act as Z-Wave network controller (primary or secondary), so a security enabled controller is needed for take full advantage of all functionality for the device. It also supports the Over The Air (OTA) feature for the product's firmware upgrade.

The encryption modes that the Z-Wave to DALI controller supports are S0, S2 Unauthenticated. When the it is being included into a Z-Wave network, you can use your primary controller/gateway to enable one encryption mode or disable encryption. (The primary controller/gateway shall support encryption mode configuration).

Installation Guide

Please read carefully the enclosed user manual before installation of the Z-Wave to DALI controller, in order to ensure an error-free functioning.

ATTENTION: Prior to the assembly of the product, the voltage network has to be switched OFF and ensured against re-switching.

Inclusion (adding to a Z-Wave network)

1. Set primary controller/gateway into inclusion mode (Please refer to your primary controllers manual on how to turn your controller into inclusion).

2. Power on the Z-Wave to DALI controller, make sure the it does not belong to any Z-Wave network (please refer to the part "How to check whether the Z-Wave to DALI controller included to a network" of this manual).

1) When the controlled DALI drivers flash quickly for 6 seconds, it means the controller does not belong to any network. Triple press the "Inclusion/Exclusion" button, it will be set into inclusion mode automatically, and waiting to be included.

2) When the controlled DALI drivers are under solid on status, it means the Z-Wave to DALI controller has already been included into a network. First you have to set it into exclusion mode, once excluded, it will be set into inclusion mode automatically, and waiting to be included.

The controlled DALI drivers stay solid on 3s to indicate successful inclusion.

Exclusion (removing from a Z-Wave network)

There are two exclusion methods:

Method 1: Exclusion from the primary controller/gateway as follows:

1. Set the primary controller/gateway into exclusion mode (Please refer to your primary controllers manual on how to set your controller into exclusion).
2. Triple press the "inclusion/exclusion" button, the Z-Wave to DALI controller will be set to exclusion mode, the controlled DALI drivers will flash quickly for 6 seconds, and waiting to be excluded, then the controlled DALI drivers stay solid on 3s to indicate successful exclusion.

There are 3 methods for the Z-Wave to DALI controller to quit "exclusion mode". Once it quits "exclusion mode", the controlled DALI drivers will stop the fast flash status.

1. Automatically quits after successful exclusion.
2. Quits after 10 seconds timeout.
3. Power off and power on the Z-Wave to DALI controller.

(Note: When the Z-Wave to DALI controller already included to a network, triple press "inclusion/exclusion" button, it will be set into exclusion mode and quit exclusion mode alternatively.)

Method 2: Factory reset the Z-Wave to DALI controller will force it to be excluded from a network. (please refer to the part "Factory Reset" of this manual)

Note: Factory reset is not recommended for exclusion, please use this procedure only if the primary controller/gateway is missing or otherwise inoperable.

How to check whether the Z-Wave to DALI controller already included to a network

There is one method to check whether the Z-Wave to DALI controller already included to a network: Power off and power on it, if the controlled DALI drivers flash quickly for 6 seconds, it means the Z-Wave to DALI controller does not belong to any network. When the controlled DALI drivers are under solid on status, it means the Z-Wave to DALI controller has already been included into a network.

Factory Reset

Press and hold down "inclusion/exclusion" button for over 10 seconds, the controlled DALI drivers will flash quickly and then stay solid on 3s to indicate successful factory reset.

Association

Z-Wave devices control other Z-Wave devices. The relationship between one device controlling another device is called association. In order to control a different device, the controlling device needs to maintain a list of devices that will receive controlling commands. These lists are called association groups and they are always related to certain events (e.g. button pressed). In case the event happens all devices stored in the respective association group will receive a common wireless command.

Association Groups:

Group Identifier	Group Name	Max Nodes	Description
1	Lifeline	5	<ol style="list-style-type: none"> 1. Z-Wave to DALI controller Factory Reset, send Command Class "Device Reset Locally Notification V1" to associated devices of this group to report factory reset information when factory reset the controller. 2. When Z-Wave to DALI controller ON/OFF or light intensity value changes, send Command Class "Basic Report" to associated devices of this group to report ON/OFF or light intensity value information.

Set and unset associations:

(Note: All association information will be cleared automatically once the Z-Wave to DALI controller is excluded from a network.)

Set association by operating primary controller/gateway to send packets to the Z-Wave to DALI controller:

The primary controller/gateway sends packets to the Z-Wave to DALI using "Command Class ASSOCIATION"

Operating the device

Short press inclusion/exclusion button on the Z-Wave to DALI controller to switch ON/OFF the DALI control

gears on the DALI circuit.

Node Information Frame

The Node Information Frame is the business card of a Z-Wave device. It contains information about the device type and the technical capabilities. The inclusion and exclusion of the device is confirmed by sending out a Node Information Frame. Beside this it may be needed for certain network operations to send out a Node Information Frame.

How to send out Node Information Frame:

When the Z-Wave to DALI controller is set to inclusion/exclusion mode again, it will send out Node Information Frame, there are 2 kinds of operation as follows:

1. When the controlled DALI drivers are under solid on status, triple press the "inclusion/exclusion" button, the Z-Wave to DALI controller will be set to inclusion/exclusion mode, then send out Node Information Frame.

2. When the controlled DALI drivers are under fast flashing status for 6 seconds, which means the Z-Wave to DALI controller is under inclusion mode, there are two kinds of operation:

- 1) Triple press inclusion/exclusion button, the Z-Wave to DALI controller will be set to inclusion mode again, and send out Node Information Frame.

- 2) Power off and power on the Z-Wave to DALI controller, it will be set to inclusion mode automatically, and send out Node Information Frame.

Technical Data

Wireless Range	up to 100 m outside, on average up to 40 m inside buildings
Radio Frequency	868.42 MHz (EU)/908.42 MHz (US)/921.42MHz (ANZ) /869.0 MHz (RU)
SDK	6.71.01
Explorer Frame Support	Yes
Device Type	Light Dimmer Switch
Generic Device Class	Switch Multilevel
Specific Device Class	Power Switch Multilevel
Routing	Yes
FLIRS	No

Z-Wave Plus Info

Parameter	Value
Z-Wave Plus Version	1
Role Type	Slave Always On
Node Type	ZWAVEPLUS
Installer Icon Type	0x0600 (ICON_TYPE_GENERIC_LIGHT_DIMMER_SWITCH)
User Icon Type	0x0600 (ICON_TYPE_GENERIC_LIGHT_DIMMER_SWITCH)

Manufacturer Specific

Parameter	Value (hex)
Manufacturer ID	0x0330
Product Type ID	0x0200(EU), 0x0201(US), 0x0202(ANZ), 0x021A(RU)
Product ID	0xD002

SUPPORTED COMMAND CLASS

Node Info		Support S2
COMMAND_CLASS_ZWAVEPLUS_INFO	V2	
COMMAND_CLASS_SECURITY	V1	
COMMAND_CLASS_SECURITY_2	V1	
COMMAND_CLASS_TRANSPORT_SERVICE	V2	
COMMAND_CLASS_SUPERVISION	V1	
COMMAND_CLASS_MANUFACTURER_SPECIFIC	V2	YES
COMMAND_CLASS_VERSION	V2	YES
COMMAND_CLASS_SWITCH_MULTILEVEL	V4	YES
COMMAND_CLASS_SCENE_ACTIVATION	V1	YES
COMMAND_CLASS_SCENE_ACTUATOR_CONF	V1	YES
COMMAND_CLASS_NOTIFICATION	V8	YES
COMMAND_CLASS_CONFIGURATION	V2	YES
COMMAND_CLASS_ASSOCIATION	V2	YES
COMMAND_CLASS_ASSOCIATION_GRP_INFO	V3	YES
COMMAND_CLASS_POWERLEVEL	V1	YES
COMMAND_CLASS_DEVICE_RESET_LOCALLY	V1	YES
COMMAND_CLASS_FIRMWARE_UPDATE_MD	V4	YES

Configuration Command Class

Parameter Number	Size	Description	Default Value
2	1	Info: Saving load state before power failure 0-shutoff load 1-turn on load 2-save load state before power failure	0
3	1	Info: Enable/disable to send the basic report to the Lifeline when the load state changed (When value set as 1, re-power on the Z-Wave to DALI controller, it will send Basic report automatically) 0-Disable to send Basic report 1-Enable to send Basic report	1
5	1	Info: Choose a cool light stage mode Choose a cool light stage mode 0=inactive of light stage mode 1=fade in and fade out mode, colors set by parameter 8 2=flash mode, colors set by parameter 8	0x00
6	1	Info: Speed of stage mode 0~0xFF: 0 is the slowest, 255 is the fastest	0xF3
7	1	Info: Execution times of stage mode 0: unlimited times 1~0xFF: execution times 1~255	0x00
8	1	Info: The hue of stage mode The hue is only valid for fade in and fade out mode, flash mode 0~0xFF: hue	0x00

Remarks: parameter number 5~8 are united parameters, it is recommended to use Configuration Bulk Set to configure synchronously.

Parameter Number Definitions

Parameter number 2 defines the load state after re-power on it:

Value 0 is off state.

Value 1 is on state.

Value 2 is the state before re-power on.

Parameter number 3 enables/disables to send Basic report to the Lifeline when load state changed:

Value 0 disables to send .

Value 1 enables to send.

Parameter number 5 defines light stage mode:

Value 0 inactivates light stage mode.

Value 1 is fade in and fade out mode with colors set by configuration parameter 8.

Value 2 is flash mode with colors set by configuration parameter 8.

Parameter number 6 defines the speed of stage mode:

Value 0~0xFF configurable, 0 is the slowest, 255 is the fastest.

Parameter number 7 defines execution times of stage mode:

Value 0 is unlimited times.

Value 1~0xFF is 1~255 times.

Parameter number 8 defines the hue of stage mode:

Value 0~0xFF is hue 0~255.

DALI Configuration

1. Select DALI Address/Group Control Mode & DT6/DT8 Control Mode:

A rotary switch is used to select Address/Group control mode & DT6/DT8 control mode.

Control Mode Switch Position	0	1	2	3	4	5	6	7
Control Mode Selected	Address & DT6	Group & DT6	Address & DT8 Tc	Group & DT8 Tc	Address & DT8 XY	Group & DT8 XY	Address & DT8 RGBWAF	Group & DT8 RGBWAF

2. Select DALI Address to be Controlled:

1) Once an address control mode is selected, use the two rotary switches for setting address number (00-64) to select the DALI address (00-63) you would like to control, the number equals to tens position plus units position.

2) Set the address number as 0, all DALI devices on the circuit will be controlled through broadcast.

3) Set the address number as X except 0 (01-64), control gear with DALI address X-1 will be controlled.

Note: if X is set as 64, control gears with DALI address 63 will be controlled by the controller.

3. Select DALI Group to be Controlled:

1) Once a group control mode is selected, use the two rotary switches for setting group number to select the DALI group (0-15 selectable) you would like to control, the number equals to tens position plus units position.

2) This DALI controller enables dimming commands and DT8 commands to be sent to 1 Group of devices on the DALI circuit.

3) When group number is set as 0, all DALI devices on the circuit will be controlled through broadcast.

4) When group number is set as X except 0 (1-15), the controller will control DALI Group X-1.

Note: Please first group all DALI control gears on the circuit by a master controller.

Please refer to the detailed Group setting table as follows:

Group Number Setting	0	1	2	3	4	5	6	7	8	9	10	11	12	13	14	15
DALI Group Selected	Broadcast	0	1	2	3	4	5	6	7	8	9	10	11	12	13	14

Wiring Diagram

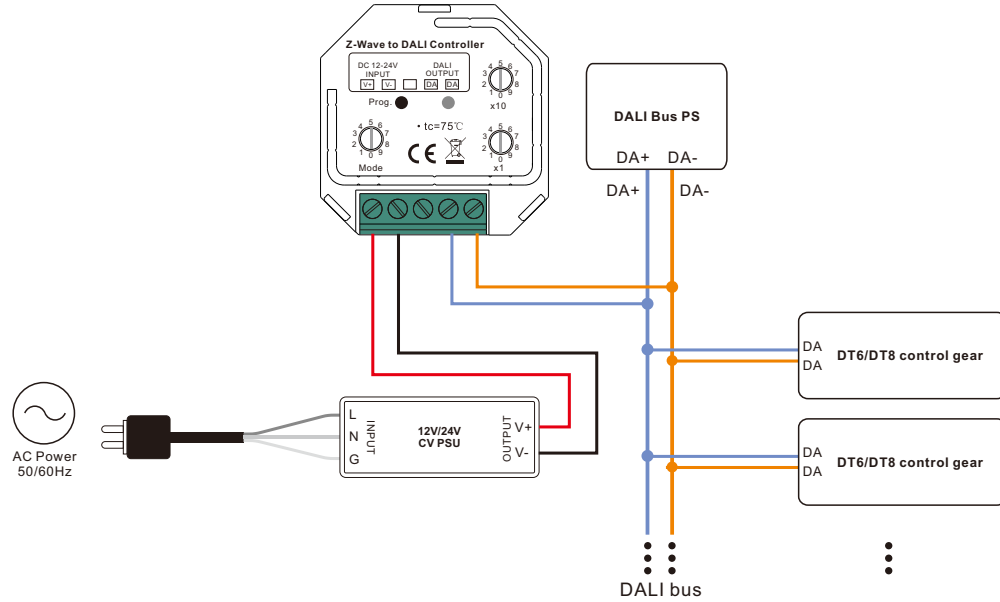

Note: if multiple controllers are installed on the DALI bus, please do not set more than one controller into the same association group, otherwise when they are controlled at the same time in the same association group through Z-Wave, the DALI commands they send to the DALI bus will conflict with each other.

Product Dimension

